

INSTALLATION AND MAINTENANCE INSTRUCTIONS 2SCU13 Series Split System Air Conditioner

WARNING

The equipment covered in this manual is to be installed by trained and experienced service and installation technicians. Improper installation, modification, service, or use can cause electrical shock, fire, explosion, or other conditions which may cause personal injury, death, or property damage. Use appropriate safety gear including safety glasses and gloves when installing this equipment.

WARNING

Risk of electrical shock. Disconnect all remote power supplies before installing or servicing any portion of the system. Failure to disconnect power supplies can result in property damage, personal injury, or death.

WARNING

Installation and servicing of air conditioning equipment can be hazardous due to internal refrigerant pressure and live electrical components. Only trained and qualified service personnel should install or service this equipment. Installation and service performed by unqualified persons can result in property damage, personal injury, or death.

WARNING

Sharp metal edges can cause injury. When installing the unit, use care to avoid sharp edges.

TABLE OF CONTENTS

INSTALLATION	2
START-UP	10
OPERATION	14
MAINTENANCE	14
CONNECTION DIAGRAMS	16
WARRANTY	18

Manufactured By
A.A.C.
A Lennox International Inc. Company
421 Monroe Street
Bellevue, OH 44811



Save these instructions for future reference

INSTALLATION

General

Read this entire instruction manual, as well as the instructions supplied in separate equipment, before starting the installation. Observe and follow all warnings, cautions, instructional labels, and tags. Failure to comply with these instructions could result in an unsafe condition and/or premature component failure.

These instructions are intended as a general guide only for use by qualified personnel and do not supersede any national or local codes in any way. The installation must comply with all provincial, state, and local codes as well as the National Electrical Code (U.S.) or Canadian Electrical Code (Canada). Compliance should be determined prior to installation.

When servicing or repairing HVAC components, ensure the fasteners are appropriately tightened. Table 1 shows torque values for fasteners.

Fastener	Torque
Stem Caps	8 ft. lbs.
Service Port Caps	8 ft. lbs.
Sheet Metal Screws	16 in. lbs.
#8 Machine Screws	16 in. lbs.
#10 Machine Screws	28 in. lbs.
Compressor Bolts	90 in. lbs.

Table 1

Inspection of Shipment

Upon receipt of equipment, carefully inspect it for possible shipping damage. If damage is found, it should be noted on the carrier's freight bill. Take special care to examine the unit inside the carton if the carton is damaged. Any concealed damage discovered should be reported to the last carrier immediately, preferably in writing, and should include a request for inspection by the carrier's agent.

If any damages are discovered and reported to the carrier **DO NOT INSTALL THE UNIT, as claim may be denied.**

Check the unit rating plate to confirm specifications are as ordered.

Location of Unit

Outdoor units operate under a wide range of weather conditions; therefore, multiple factors must be considered when positioning the unit. The unit must be positioned to give adequate clearances for sufficient airflow and servicing. Refer to Figure 1 for installation clearances.

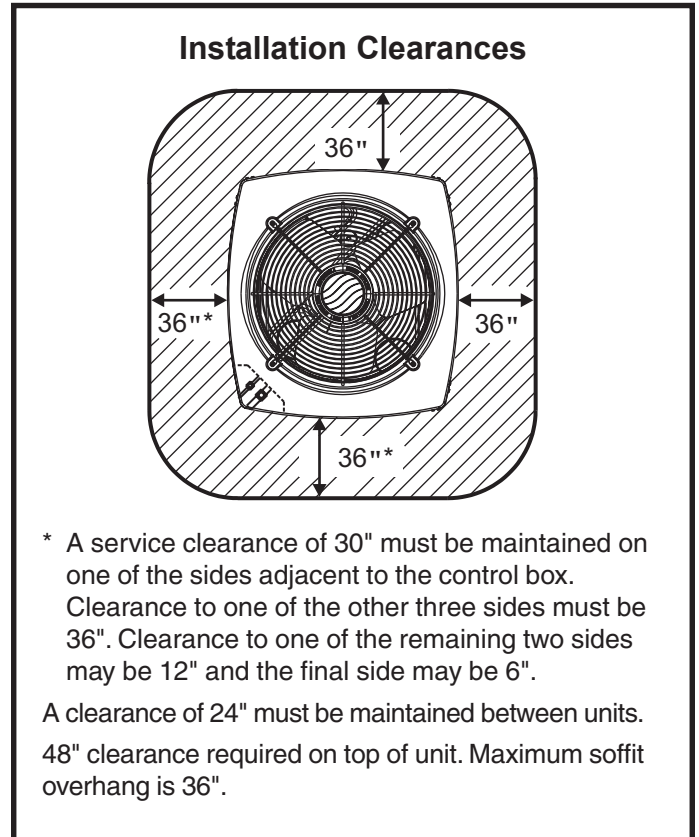

Figure 1

Slab Mounting

When installing unit at grade level, install on slab high enough above grade to allow adequate drainage of water (see Figure 2). Top of slab should be located so runoff water from higher ground will not collect around unit. Refer to roof mounting section for barrier construction if unit must face prevailing winter winds.

Roof Mounting

Install unit at a minimum of 4" above surface of the roof. Care must be taken to ensure weight of unit is properly distributed over roof joists and rafters. Either redwood or steel supports are recommended.

If unit coil cannot be mounted away from prevailing winter winds, a wind barrier should be constructed (see Figure 3). Size barrier at least the same height and width as the outdoor unit. Mount barrier 24" from the sides of the unit in the direction of the prevailing winds.

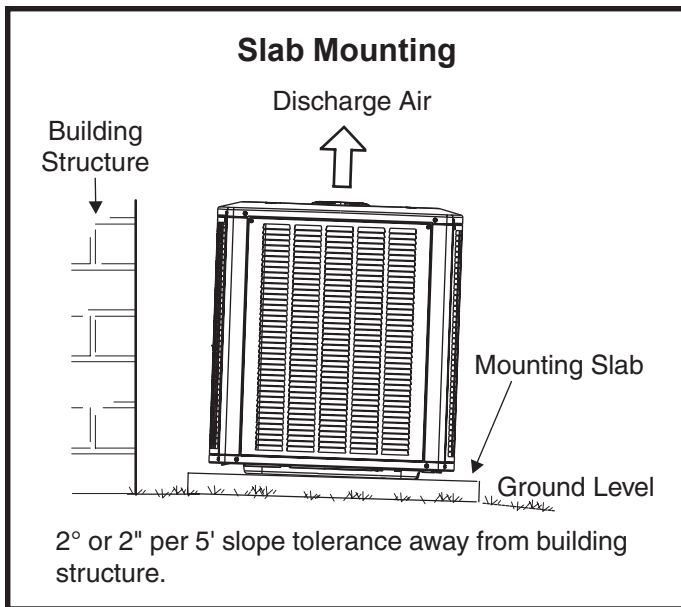

Figure 2

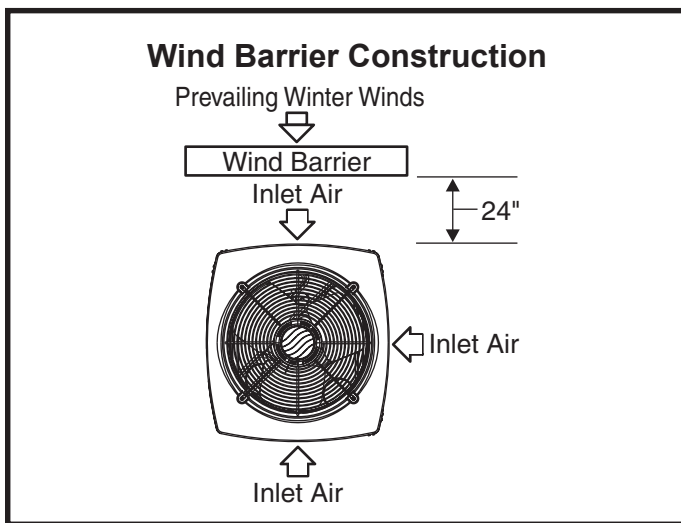

Figure 3

Electrical Wiring

All field wiring must be done in accordance with the National Electrical Code (NEC) recommendations, Canadian Electrical Code (CEC) and CSA Standards, or local codes, where applicable.

⚠ WARNING

Unit must be grounded in accordance with national and local codes. Failure to ground unit properly can result in personal injury or death.

Refer to the furnace or blower coil Installation Instructions for additional wiring application diagrams and refer to unit rating plate for minimum circuit ampacity and maximum overcurrent protection size.

1. Install line voltage power supply to unit from a properly sized disconnect switch. Any excess high voltage field wiring should be trimmed or secured away from the low voltage field wiring.
2. Ground unit at unit disconnect switch or to an earth ground. To facilitate conduit, a hole is in the bottom of the control box. Connect conduit to the control box using a proper conduit fitting. Units are approved for use only with copper conductors. 24V Class II circuit connections are made to the low voltage pigtails. A complete unit wiring diagram is located inside the unit control box cover (see also pages 16 and 17 of this instruction).
3. Install room thermostat on an inside wall that is not subject to drafts, direct sunshine, or other heat sources.
4. Install low voltage wiring from outdoor to indoor unit and from thermostat to indoor unit (see Figure 4).
5. Do not bundle any excess 24V control wire inside control box. Run control wire through installed wire tie and tighten wire tie to provide low voltage strain relief and to maintain separation of field-installed low and high voltage circuits.

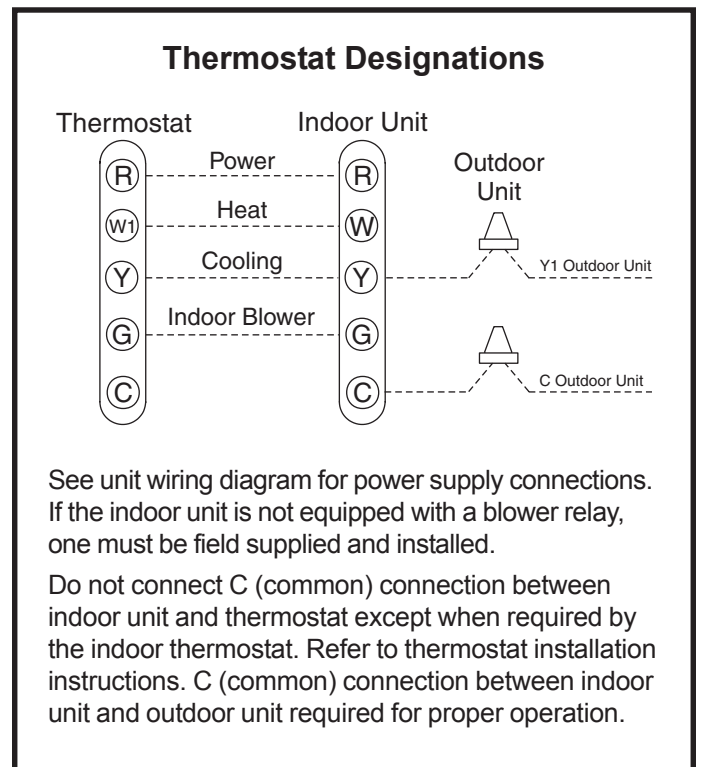

See unit wiring diagram for power supply connections. If the indoor unit is not equipped with a blower relay, one must be field supplied and installed.

Do not connect C (common) connection between indoor unit and thermostat except when required by the indoor thermostat. Refer to thermostat installation instructions. C (common) connection between indoor unit and outdoor unit required for proper operation.

Figure 4

Refrigerant Piping

Field refrigerant piping consists of liquid and suction lines from the outdoor unit (sweat connections) to the indoor coil (flare or sweat connections).

Select line set diameters from Table 2 on page 4 to ensure that oil returns to the compressor. Size vertical

suction riser to maintain minimum velocity at minimum capacity. Recommended line length is 50' or less. If more than 50' line set is required, contact Technical Services at (419) 483-4840.

Table 2 shows the diameters for line sets up to 100' although vertical lift applications and trapping requirements need to be reviewed with Technical Services for line sets over 50'.

Refrigerant Line Set Diameters (in.)					
Liquid Line					
BTUH	Line Set Length and Size				
	12 ft.	25 ft.	50 ft.	75 ft.	100 ft.
18,000	3/8	3/8	3/8	3/8	3/8
24,000	3/8	3/8	3/8	3/8	3/8
30,000	3/8	3/8	3/8	3/8	1/2
36,000	3/8	3/8	3/8	3/8	1/2
42,000	3/8	3/8	3/8	1/2	1/2
48,000	3/8	3/8	3/8	1/2	1/2
60,000	3/8	3/8	3/8	1/2	1/2

Suction Line					
BTUH	Line Set Length and Size				
	12 ft.	25 ft.	50 ft.	75 ft.	100 ft.
18,000	3/4	3/4	3/4	3/4	3/4
24,000	3/4	3/4	3/4	3/4	7/8
30,000	3/4	3/4	3/4	7/8	7/8
36,000	7/8	7/8	7/8	7/8	1-1/8
42,000	7/8	7/8	7/8	1-1/8	1-1/8
48,000	7/8	7/8	7/8	1-1/8	1-1/8
60,000	1-1/8	1-1/8	1-1/8	1-1/8	1-1/8

For installations exceeding 50', contact Technical Services at (419) 483-4840.

Table 2

Installing Refrigerant Line

During the installation of an air conditioning system, it is important to properly isolate the refrigerant line to prevent unnecessary vibration. Line set contact with the structure (wall, ceiling, or floor) may cause objectionable noise when vibration is translated into sound. As a result, more

energy or vibration can be expected. Close attention to line set isolation must be observed.

Following are some points to consider when placing and installing a high-efficiency outdoor unit:

Placement

Be aware that some localities are adopting sound ordinances based on how noisy the unit is at the neighbor's home, not at the original installation. Install the unit as far as possible from the property line. When possible, do not install the unit directly outside a bedroom window. Glass has a very high level of sound transmission. Figure 5 shows how to place the outdoor unit and line set to reduce line set vibration.

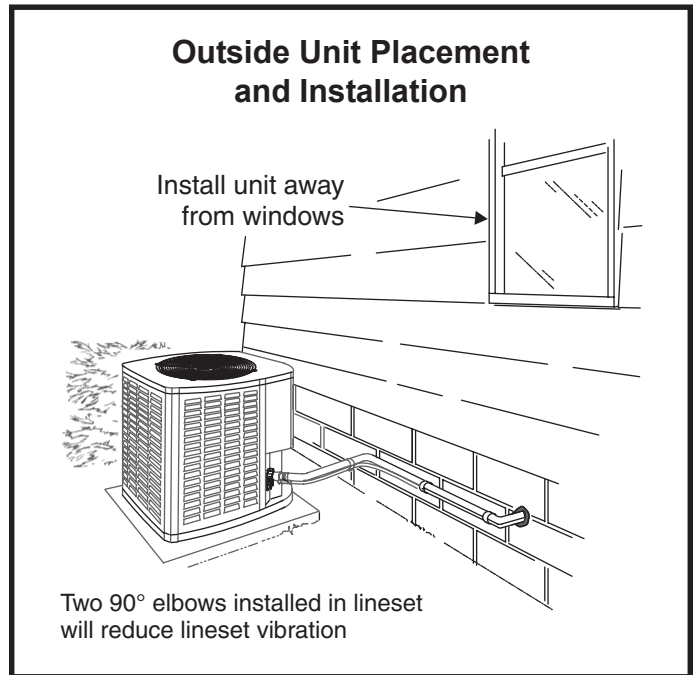

Figure 5

Line Set Isolation

Illustrations on the following pages demonstrate procedures which ensure proper refrigerant line set isolation. Figure 6 shows how to install line sets on horizontal runs. Figure 7 shows how to make a transition from horizontal to vertical. Figure 8 on page 6 shows how to install line sets on vertical runs.

Brazing Connection Procedure

1. Cut ends of refrigerant lines square (free from nicks or dents). Debur the ends. The pipe must remain round; do not pinch end of line.
2. Before making line set connections, use dry nitrogen to purge the refrigerant piping. This will help to prevent oxidation and the introduction of moisture into the system.

Refrigerant Line Sets: Installing Horizontal Runs

To hang line set from joist or rafter, use either metal strapping material or anchored heavy nylon wire ties.

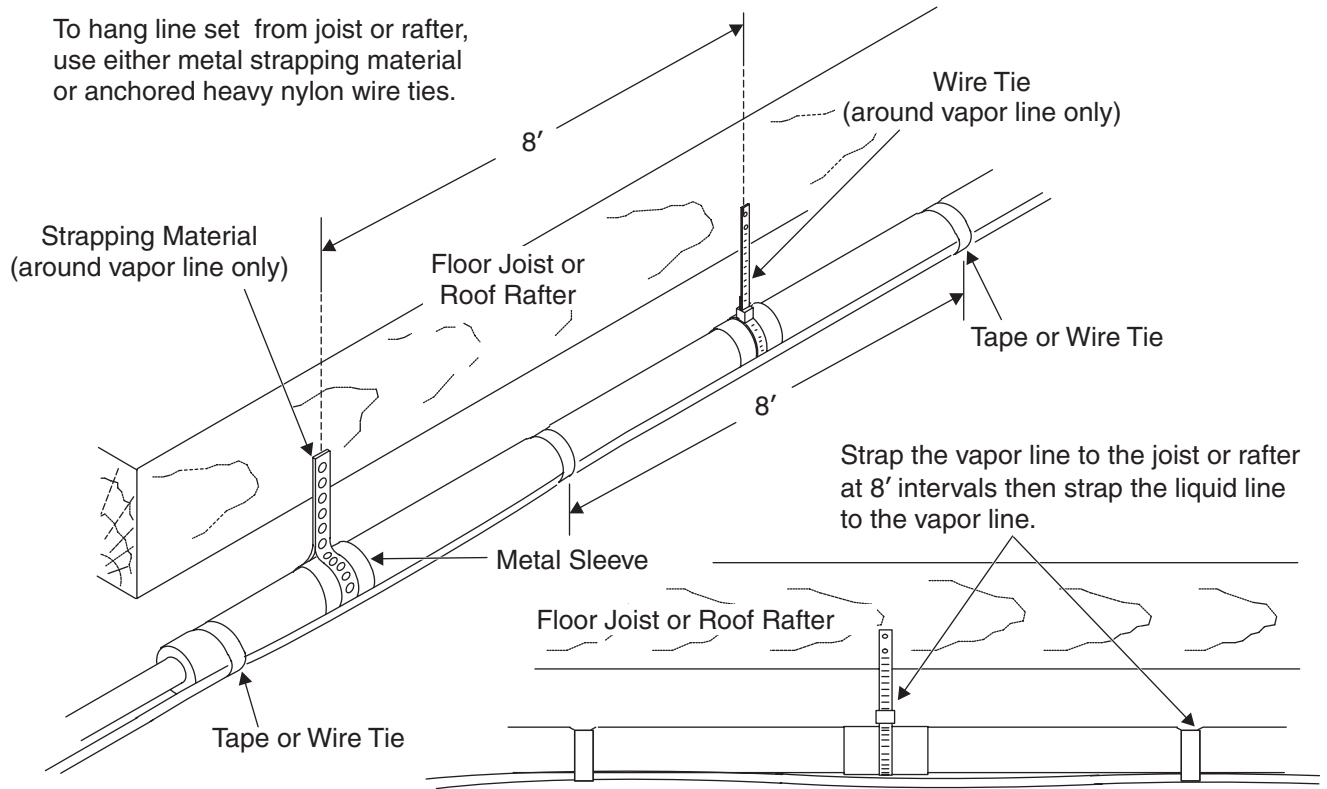

Figure 6

Refrigerant Line Sets: Transition from Vertical to Horizontal

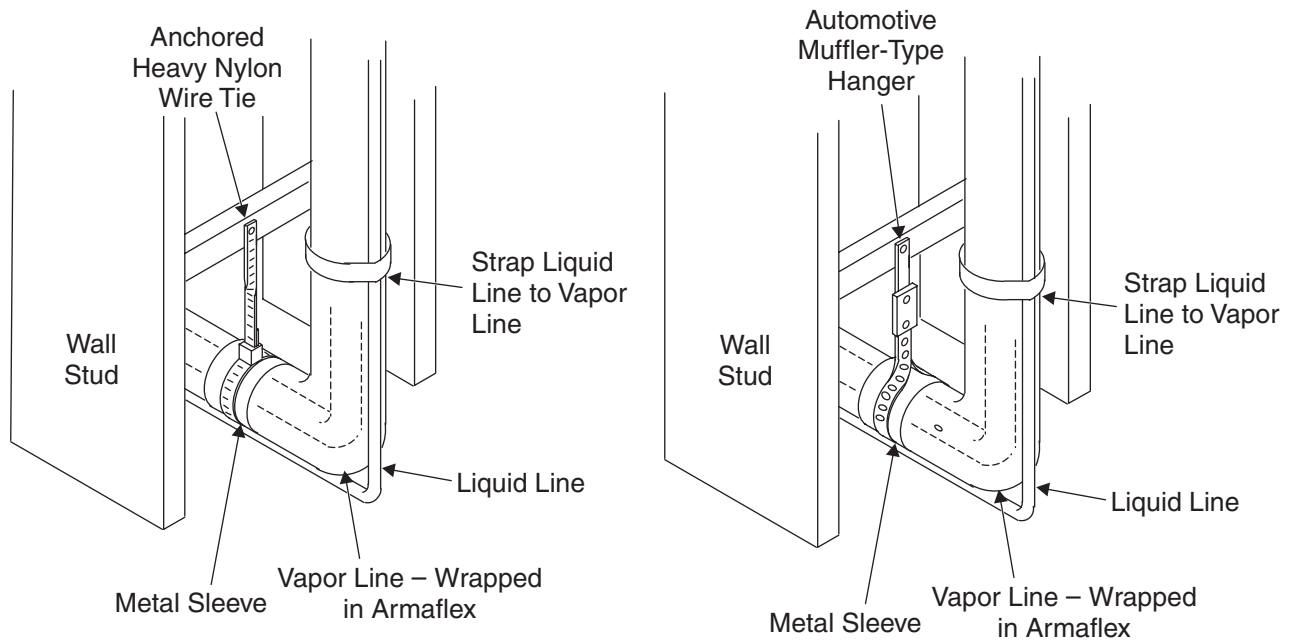

Figure 7

Refrigerant Line Sets: Installing Vertical Runs (new construction shown)

NOTE: Similar installation practices should be used if line set is to be installed on exterior of outside wall.

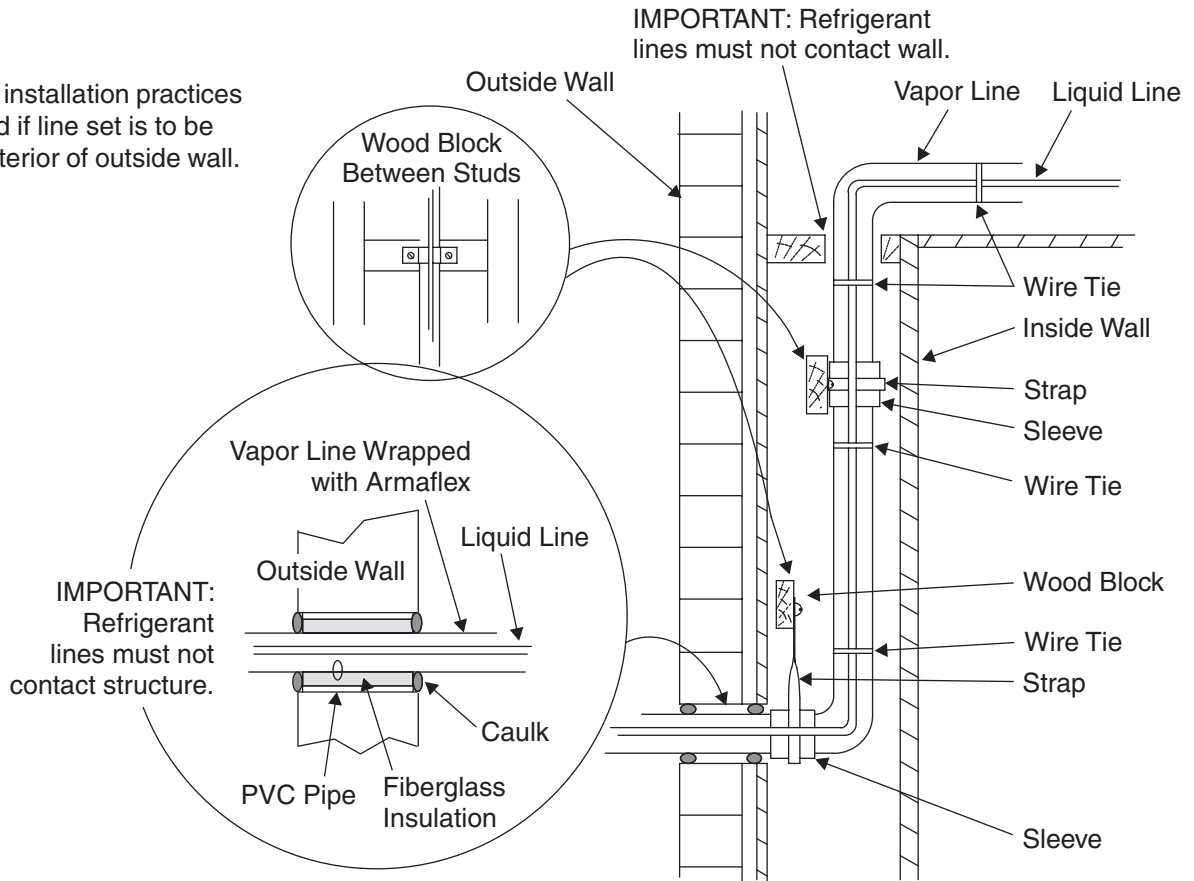

Figure 8

3. Use silver alloy brazing rods (5% or 6% silver alloy for copper-to-copper brazing or 45% silver alloy for copper-to-brass or copper-to-steel brazing) which are rated for use with HCFC-22 refrigerant.
4. Remove the Schrader core assemblies before brazing to protect them from damage due to extreme heat. Replace the cores when brazing is complete.
5. Wrap a wet cloth around the valve body and copper tube stub to protect them from heat damage during brazing.
6. Braze the line set to the service valve. Quench the joints with water or a wet cloth to prevent heat damage to the valve core and opening port. **The tube end must stay bottomed in the fitting during final assembly to ensure proper seating, sealing, and rigidity.**
7. Install the factory-supplied fixed orifice (or thermal expansion valve which is sold separately and which is approved for use with HCFC-22 refrigerant) in the liquid line at the indoor coil.

Refrigerant Metering Device

2SCU13 units are designed for use with either fixed orifice or TXV systems. Refer to the appropriate following section for information on installing the chosen refrigerant metering device.

Fixed Orifice Systems

2SCU13 units are shipped with a fixed orifice refrigerant metering device. Replace the existing indoor unit fixed orifice with the orifice supplied with this unit. Place the supplied fixed orifice sticker on the indoor cabinet after installation. See Table 3 for the proper fixed orifice size for each unit. In nonstandard applications, the provided fixed orifice may not be appropriately sized.

Install the fixed orifice as shown in Figure 9. Do not twist cap tubes when loosening the seal nut from the orifice housing. Use wrench to back up the distributor.

Expansion Valve Systems

Expansion valves equipped with Chatleff-type fittings are available from the manufacturer. See Table 4 for proper TXV for each unit.

Fixed Orifice Data

Model	Part Number	Drill Size
2SCU13-18	100484-07	.053
2SCU13-24	100484-12	.062
2SCU13-30	100484-19	.070
2SCU13-36	100484-24	.076
2SCU13-42	100484-30	.082
2SCU13-48	100484-38	.091
2SCU13-60	100484-45	.099

Table 3

Metering Device Installation

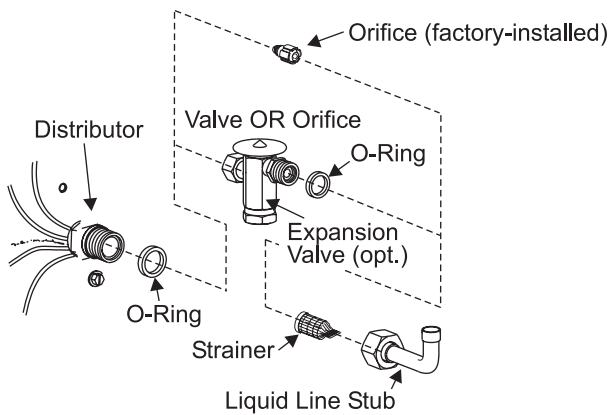

Figure 9

TXV Data

Model	Part Number
2SCU13-18, -24, -30, -36	26K34
2SCU13-42, -48	26K35
2SCU13-60	91M01

Table 4

To install an expansion valve (see Figure 9):

1. Separate the distributor assembly and remove the piston orifice and used teflon seal. Insert nozzle end of

the expansion valve along with a new teflon seal into the distributor and tighten to 20 – 30 ft. lbs. Use backup wrench on all wrench flats. **Overtightening will crush the teflon seal and may cause a leak.**

2. Attach liquid line portion of distributor assembly along with new teflon seal to the inlet of the expansion valve. Tighten to 20 – 30 ft. lbs. Use backup wrench on all wrench flats. **Overtightening will crush the teflon seal and may cause a leak.**
3. Connect the external equalizer line to the equalizer port on the suction line and tighten to 8 ft. lbs.
4. Strap the superheat sensing bulb to the suction header.

If installing an expansion valve on an indoor coil that previously used a fixed orifice, be sure to remove the existing fixed orifice. Failure to remove a fixed orifice when installing an expansion valve to the indoor coil will result in improper operation and damage to the system.

Manifold Gauge Set

When checking the unit charge, use a manifold gauge set that is equipped with “low loss” hoses. Do not use a manifold gauge set with anything other than a “low loss” hose.

Liquid and Suction Line Service Valves

The liquid line and suction line service valves and service ports are used for leak testing, evacuating, charging, and checking charge.

Each valve is equipped with a service port which has a factory-installed Schrader valve (see Figure 10 on page 8). A service port cap protects the Schrader valve from contamination and serves as the primary leak seal.

To Access the Schrader Port:

1. Remove the service port cap with an adjustable wrench.
2. Connect gauge to the service port.
3. When testing is completed, replace service port cap. Tighten finger tight, then an additional 1/6 turn.

To Open Liquid or Suction Line Service Valve:

1. Remove stem cap with an adjustable wrench.
2. Use a service wrench with a hex-head extension to back the stem out counterclockwise as far as it will go. Use a 3/16" hex head extension for liquid line service valves and a 5/16" extension for suction line service valves.

3. Replace the stem cap. Tighten finger tight, then tighten an additional 1/6 turn.

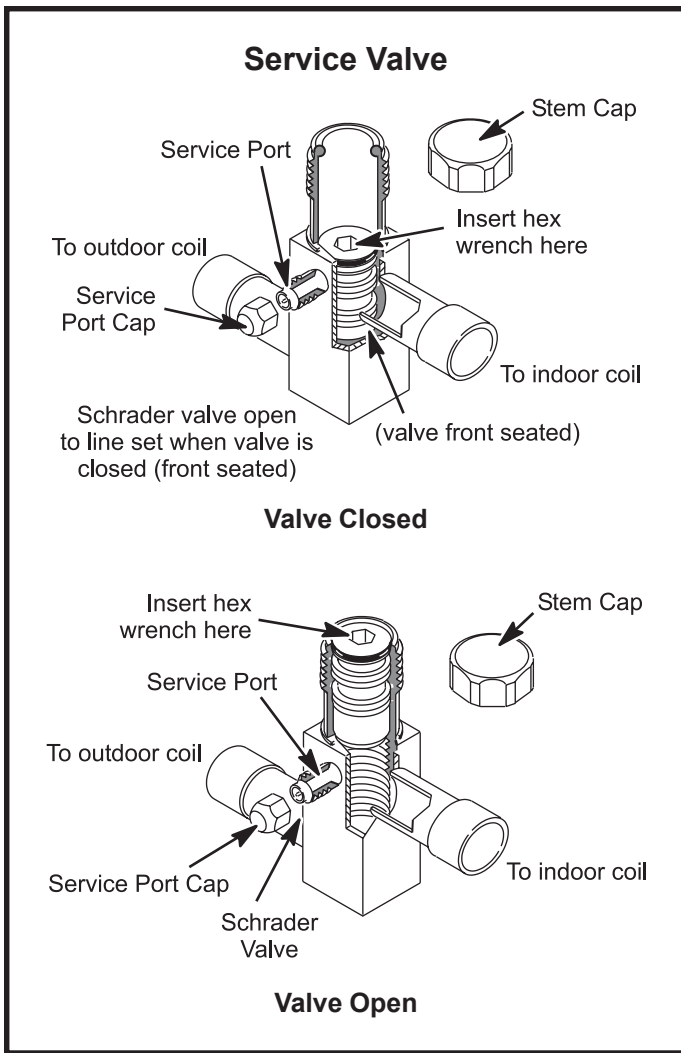

Figure 10

To Close Liquid or Suction Line Service Valve:

1. Remove the stem cap with an adjustable wrench.
2. Use a service wrench with a hex-head extension to turn the stem clockwise to seat the valve. Tighten firmly.
3. Replace the stem cap. Tighten finger tight, then tighten an additional 1/6 turn.

Suction Line (Ball Type) Service Valve

Suction line (ball type) service valves function the same way as the other valves; the difference is in the construction (see Figure 11).

The ball valve is equipped with a service port with a factory-installed Schrader valve. A service port cap protects the Schrader valve from contamination and serves as the primary seal.

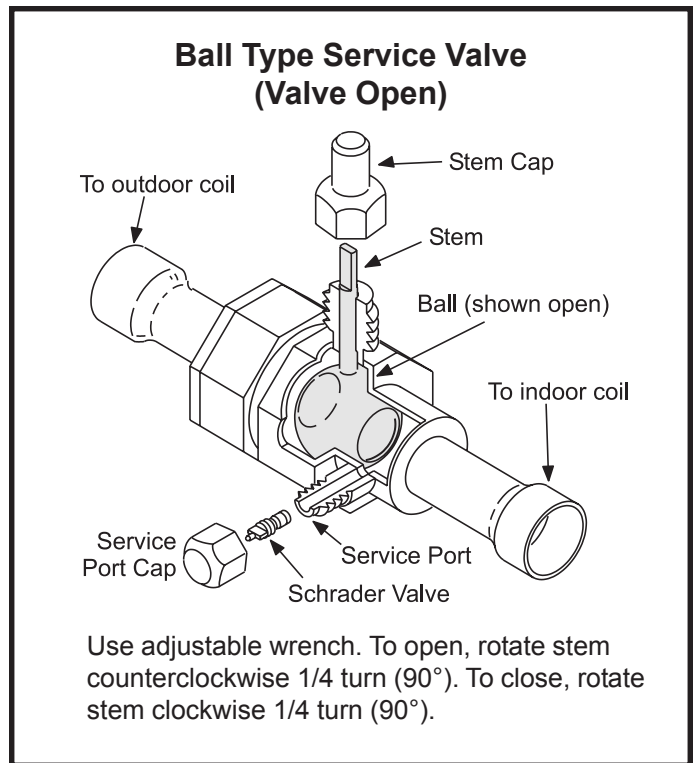

Figure 11

Leak Testing

After the line set has been connected to the indoor and outdoor units, the line set connections and indoor unit must be checked for leaks.

⚠ WARNING

Refrigerant can be harmful if inhaled. Refrigerant must always be used and recovered responsibly. Incorrect or irresponsible use of refrigerant can result in personal injury or death.

⚠ WARNING

Never use oxygen to pressurize refrigeration or air conditioning systems. Oxygen will explode on contact with oil and could cause personal injury or death.

Using an Electronic Leak Detector

1. Connect the high pressure hose of the manifold gauge set to the suction valve service port. (Normally the high pressure hose is connected to the liquid line port; however, connecting it to the suction ports helps to protect the manifold gauge set from damage caused by high pressure.)

2. With both manifold valves closed, connect the cylinder of HCFC-22 refrigerant. Open the valve on the HCFC-22 cylinder (vapor only).
3. Open the high pressure side of the manifold to allow HCFC-22 into the line set and indoor unit. Weigh in a trace amount of HCFC-22. (A trace amount is a maximum of 2 oz. of refrigerant or 3 lbs. pressure.) Close the valve on the HCFC-22 cylinder and the valve on the high pressure side of the manifold gauge set. Disconnect the HCFC-22 cylinder.
4. Connect a cylinder of nitrogen with a pressure regulating valve to the center port of the manifold gauge set.
When using high pressure gas such as nitrogen for this purpose, be sure to use a regulator that can control the pressure down to 1 or 2 psig.
5. Adjust nitrogen pressure to 150 psig. Open the valve on the high side of the manifold gauge set to pressurize the line set and the indoor coil.
5. Evacuate the line set and indoor unit to a minimum of 500 microns or lower. During the early stages of evacuation, it is desirable to close the manifold gauge valve at least once to determine if there is a rapid rise in pressure. A rapid rise in pressure indicates a relatively large leak. If this occurs, the leak testing procedure must be repeated.
6. When 500 microns or lower is maintained, close the manifold gauge valves, turn off the vacuum pump, and disconnect the manifold gauge center port hose from the vacuum pump. Attach the manifold gauge center port hose to a nitrogen cylinder with pressure regulator set to 150 psig and purge the hose. Open the manifold gauge valves to break the vacuum in the line set and indoor unit. Close the manifold gauge valves.
7. Shut off the nitrogen cylinder and remove the manifold gauge hose from the cylinder. Open the manifold gauge valves to release the nitrogen from the line set and indoor unit.
8. Reconnect the manifold gauge to the vacuum pump, turn the pump on, and continue to evacuate the line set and indoor unit until 500 microns is maintained within a 20-minute period after shutting off the vacuum pump and closing the manifold gauge valves.
9. When the requirements above have been met, disconnect the manifold hose from the vacuum pump. Open the service valves to break the vacuum in the line set and indoor unit.

Evacuation

Evacuating the system of noncondensables is critical for proper operation of the unit. Noncondensables are defined as any gas that will not condense under temperatures and pressures present during operation of an air conditioning system. Noncondensables and water vapor combine with refrigerant to produce substances that corrode copper piping and compressor parts.

WARNING

Do not use a compressor to evacuate a system. Avoid deep vacuum operation. Extremely low vacuums can cause internal arcing and compressor failure. Danger of equipment damage. Damage caused by deep vacuum operation will void warranty.

Use a thermocouple or thermistor electronic vacuum gauge that is calibrated in microns. Use an instrument that reads down to 50 microns.

1. Connect the manifold gauge set to the service valve ports as follows:
 - Low pressure gauge to suction line service valve
 - High pressure gauge to liquid line service valve
2. Connect micron gauge.
3. Connect the vacuum pump (with vacuum gauge) to the center port of the manifold gauge set.
4. Open both manifold valves and start vacuum pump.

START-UP

⚠ CAUTION

If unit is equipped with a crankcase heater, it should be energized 24 hours before unit start-up to prevent compressor damage as a result of slugging.

1. Rotate fan to check for frozen bearings or binding.
2. Inspect all factory and field-installed wiring for loose connections.
3. After evacuation is complete, open liquid line and suction line service valves to release refrigerant charge (contained in outdoor unit) into system.
4. Replace the stem caps and secure finger tight, then tighten an additional 1/6 of a turn.
5. Check voltage supply at the disconnect switch. The voltage must be within the range listed on the unit nameplate. If not, do not start equipment until the power company has been consulted and the voltage condition corrected.
6. Set thermostat for cooling demand, turn on power to indoor blower and close the outdoor unit disconnect switch to start the unit.
7. Recheck unit voltage with unit running. Power must be within range shown on unit nameplate.

Refrigerant Charging

Units are factory charged with the amount of HCFC-22 refrigerant indicated on the unit rating plate. This charge is based on a matching indoor coil and outdoor coil with 15' line set. For varying lengths of line set, refer to Table 5 for refrigerant charge adjustment.

Refrigerant Charge Adjustment	
Liquid Line Set Diameter	Oz. per 5 ft. adjust from 15 ft. line set*
3/8 in.	3 oz. per 5 ft.

* If line length is **greater than 15 ft.**, add this amount.
If line length is **less than 15 ft.**, remove this amount.

Table 5

If the system is void of refrigerant, clean the system using the procedure described below.

1. Use dry nitrogen to pressurize the system and check for leaks. Repair leaks, if possible.
2. Evacuate the system to remove as much of the moisture as possible.
3. Use dry nitrogen to break the vacuum.
4. Evacuate the system again.
5. Weigh the appropriate amount of HCFC-22 refrigerant (listed on unit nameplate) into the system.
6. Monitor the system to determine the amount of moisture remaining in the oil. Use a test kit to verify that the moisture content is within the kit's dry color range. It may be necessary to replace the filter drier several times to achieve the required dryness level. **If system dryness is not verified, the compressor will fail in the future.**

The outdoor unit should be charged during warm weather. However, applications arise in which charging must occur in the colder months. The method of charging is determined by the unit's **refrigerant metering device** and the **outdoor ambient temperature**.

Measure the liquid line temperature and the outdoor ambient temperature as outlined below:

1. Connect the manifold gauge set to the service valve ports as follows:
 - Low pressure gauge to suction line service valve
 - High pressure gauge to liquid line service valve
2. Close manifold gauge set valves. Connect the center manifold hose to an upright cylinder of HCFC-22.
3. If room temperature is below 70°F, set the room thermostat to call for heat. This will create the necessary load for properly charging the system in the cooling cycle.
4. Use a digital thermometer to record the outdoor ambient temperature.
5. When the heating demand has been satisfied, switch the thermostat to cooling mode with a set point of 68°F. When pressures have stabilized, use a digital thermometer to record the liquid and suction line temperatures.
6. The outdoor temperature will determine which charging method to use. Proceed with the appropriate charging method.

Charge Using Weigh-In Method (Fixed Orifice/TXV Systems)

If the system is void of refrigerant, or if the outdoor ambient temperature is cool, first locate and repair any leaks then use the weigh-in method to charge the unit.

1. Recover the refrigerant from the unit.
2. Conduct a leak check, then evacuate as previously outlined.
3. Weigh in the charge according to the total amount shown on the unit nameplate.

If weighing facilities are not available or if unit is being charged during warm weather, follow one of the other procedures outlined below.

Charge Using Subcooling Method (Fixed Orifice/TXV Systems) – Outdoor Temperatures 65°F or Above

If charging a fixed orifice or TXV system when the outdoor ambient temperature is 65°F or above, the subcooling method can be used to charge the unit.

1. With the manifold gauge hose on the liquid service port and the unit operating stably, use a digital thermometer to record the liquid line temperature.
2. At the same time, record the liquid line pressure reading.
3. Use a temperature/pressure chart for HCFC-22 to determine the saturation temperature for the liquid line pressure reading.
4. Subtract the liquid line temperature from the saturation temperature (according to the chart) to determine subcooling.

_____ ° Saturation Temperature °F

– _____ ° Liquid Line Temperature °F

= _____ ° Subcooling Value °F

5. Compare the subcooling value with those shown in Table 6. If subcooling is greater than shown, recover some refrigerant. If subcooling is less than shown, add some refrigerant.

Charge Using Superheat Method (Fixed Orifice Systems) – Outdoor Temperatures 65°F or Above

1. With the manifold gauge hose on the suction service port and the unit operating stably, use a digital thermometer to record the suction line temperature.
2. At the same time, record the suction line pressure reading.

Outdoor Temp. °F	Liquid Subcooling (±1°F)						
	-18	-24	-30	-36	-42	-48	-60
65	13	13	7	14	15	9	13
75	10	11	5	13	13	9	12
85	8	10	5	11	11	9	11
95	7	10	4	9	9	9	10
105	6	9	3	8	7	9	9
115	3	6	2	6	5	8	8

Table 6

3. Use a temperature/pressure chart for HCFC-22 to determine the saturation temperature for the suction line pressure reading.
4. Subtract the saturation temperature (according to the chart) from the suction line temperature to determine the superheat.

_____ ° Suction Line Temperature °F

– _____ ° Saturation Temperature °F

= _____ ° Superheat Value °F
5. Compare the superheat value with those shown in Table 7 on page 12. If superheat is greater than shown, add some refrigerant. If superheat is less than shown, recover some refrigerant.

Charge Using Approach Method (TXV Systems) – Outdoor Temperatures 65°F or Above

The following procedure is intended as a general guide and is for use on expansion valve systems only. For best results, indoor temperature should 70°F to 80°F. Monitor system pressures while charging.

1. Record outdoor ambient temperature using a digital thermometer.
2. Attach high pressure gauge set and operate unit for several minutes to allow system pressures to stabilize.
3. Compare stabilized pressures with those provided in Table 9 on page 13. Minor variations in these pressures may be expected due to differences in installations. **Significant differences could mean that the system is not properly charged or that a problem exists with some component in the system.**

**Superheat Values for
Fixed Orifice Systems
(80°DB/67°WB Return Air)**

Outdoor Ambient Temp. °F	Superheat °F
60	38
65	35
70	30
75	26
80	22
85	18
90	12
95	8
100	5
105	0

Table 7

Pressures higher than those listed indicate that the system is overcharged. Pressures lower than those listed indicate that the system is undercharged. Verify adjusted charge using the approach method.

- Use the same digital thermometer to check liquid line temperature.
- Subtract the outdoor ambient temperature from the liquid line temperature to determine the approach temperature.

$$\begin{aligned}
 & \text{_____}^\circ \quad \text{Liquid Line Temperature } ^\circ\text{F} \\
 - & \text{_____}^\circ \quad \text{Outdoor Ambient Temperature } ^\circ\text{F} \\
 = & \text{_____}^\circ \quad \text{Approach Temperature } ^\circ\text{F}
 \end{aligned}$$

- Compare the approach value with those shown in Table 8. If the values do not agree with those provided in Table 8, add refrigerant to lower the approach temperature or recover refrigerant from the system to increase the approach temperature.

Check Charge Using Normal Operating Pressures

Use Table 9 to perform maintenance checks. Table 9 is not a procedure for charging the system. Minor variations in these pressures may be due to differences in installations. Significant deviations could mean that the system is not properly charged or that a problem exists with some component in the system.

Approach Values for TXV Systems

Model	-18	-24	-30	-36	-42	-48	-60
Temp. °F	6	10	11	9	5	5	8

Approach value is the liquid line temperature minus the outdoor ambient temperature ($\pm 1^\circ\text{F}$).

NOTE: For best results, use the same digital thermometer to check both outdoor ambient and liquid temperatures.

Table 8

Normal Operating Pressures

Outdoor Coil Entering Air Temperature	Model													
	-18		-24		-30		-36		-42		-48		-60	
	L	S	L	S	L	S	L	S	L	S	L	S	L	S
Expansion Valve (TXV)														
65°F	141	80	147	79	141	76	145	74	143	78	145	80	151	76
75°F	166	81	173	80	167	77	170	76	167	80	170	81	177	78
85°F	195	82	218	82	195	78	201	77	198	81	198	82	207	79
95°F	222	83	234	82	227	80	234	78	231	82	230	84	240	80
105°F	258	85	267	84	260	81	268	79	268	84	265	85	277	81
115°F	294	86	307	85	299	83	309	81	308	85	303	86	318	83
Fixed Orifice (RFC)														
65°F	144	73	147	68	140	66	150	67	147	70	145	70	150	67
75°F	167	78	173	74	166	71	176	72	171	75	170	75	177	72
85°F	196	82	203	79	196	76	205	76	198	78	198	80	207	77
95°F	225	84	238	83	227	80	237	79	228	81	230	84	239	80
105°F	256	86	272	86	262	83	273	81	262	84	264	86	274	83
115°F	293	88	317	88	302	86	314	84	300	85	301	88	315	85

L – Liquid S – Suction

Values provided above are typical pressures. Indoor unit matchup, indoor air quality, and indoor load will cause pressures to vary.

Table 9

OPERATION

Outdoor unit and indoor blower cycle on demand from the room thermostat. When the thermostat blower switch is moved to the ON position, the indoor blower operates continuously.

MAINTENANCE

⚠ WARNING

Before performing maintenance operations on system, turn the electric power to unit OFF at disconnect switch(es). Unit may have multiple power supplies. Electrical shock could cause personal injury or death.

Maintenance and service must be performed by a qualified installer or service agency.

At the beginning of each cooling season, the system should be checked as follows:

1. Clean and inspect condenser coil. Coil may be flushed with a water hose. Be sure the power is off before using water to clean the coil.
2. Outdoor fan motor is pre-lubricated and sealed. No further lubrication is needed.
3. Visually inspect connecting lines and coils for evidence of oil leaks.
4. Check wiring for loose connections.
5. Check for correct voltage at unit (with unit operating).
6. Check amp-draw outdoor fan motor.

Unit nameplate _____ Actual _____

NOTE – If owner complains of insufficient cooling, the unit should be gauged and refrigerant charge checked. Refer to the **Refrigerant Charging** section on page 10.

Indoor Coil

1. Clean coil, if necessary.
2. Check connecting lines and coils for evidence of oil leaks.
3. Check condensate pan line and clean, if necessary.

Indoor Unit

1. Clean or change filters.
2. Adjust blower speed for cooling. Measure the pressure drop over the coil to determine the correct blower CFM.
3. Belt drive blowers: Check belt for wear and proper tension.
4. Check all wiring for loose connections.

5. Check for correct voltage at unit (with unit operating).

6. Check amp-draw on blower motor.

Unit nameplate _____ Actual _____

Start-Up and Performance Checklist

Job Name _____ Job No. _____ Date _____

Job Location _____ City _____ State _____

Installer _____ City _____ State _____

Unit Model No. _____ Serial No. _____

Service Technician _____ Nameplate Voltage _____

Rated Load Ampacity _____ Compressor _____ Outdoor Fan _____

Maximum Fuse or Circuit Breaker _____

Electrical Connections Tight? Indoor Filter Clean? Supply Voltage (Unit Off) _____

Indoor Blower RPM _____ S.P. Drop Over Indoor (Dry) _____

Outdoor Coil Entering Air Temperature _____ Voltage with Compressor Operating _____

Discharge Pressure _____ Vapor Pressure _____

Refrigerant Charge Checked? Outdoor Fan Checked?

Refrigerant Lines: Leak Checked? Properly Insulated?

Service Valves: Fully Opened? Caps Tight?

Thermostat: Calibrated? Properly Set? Level?

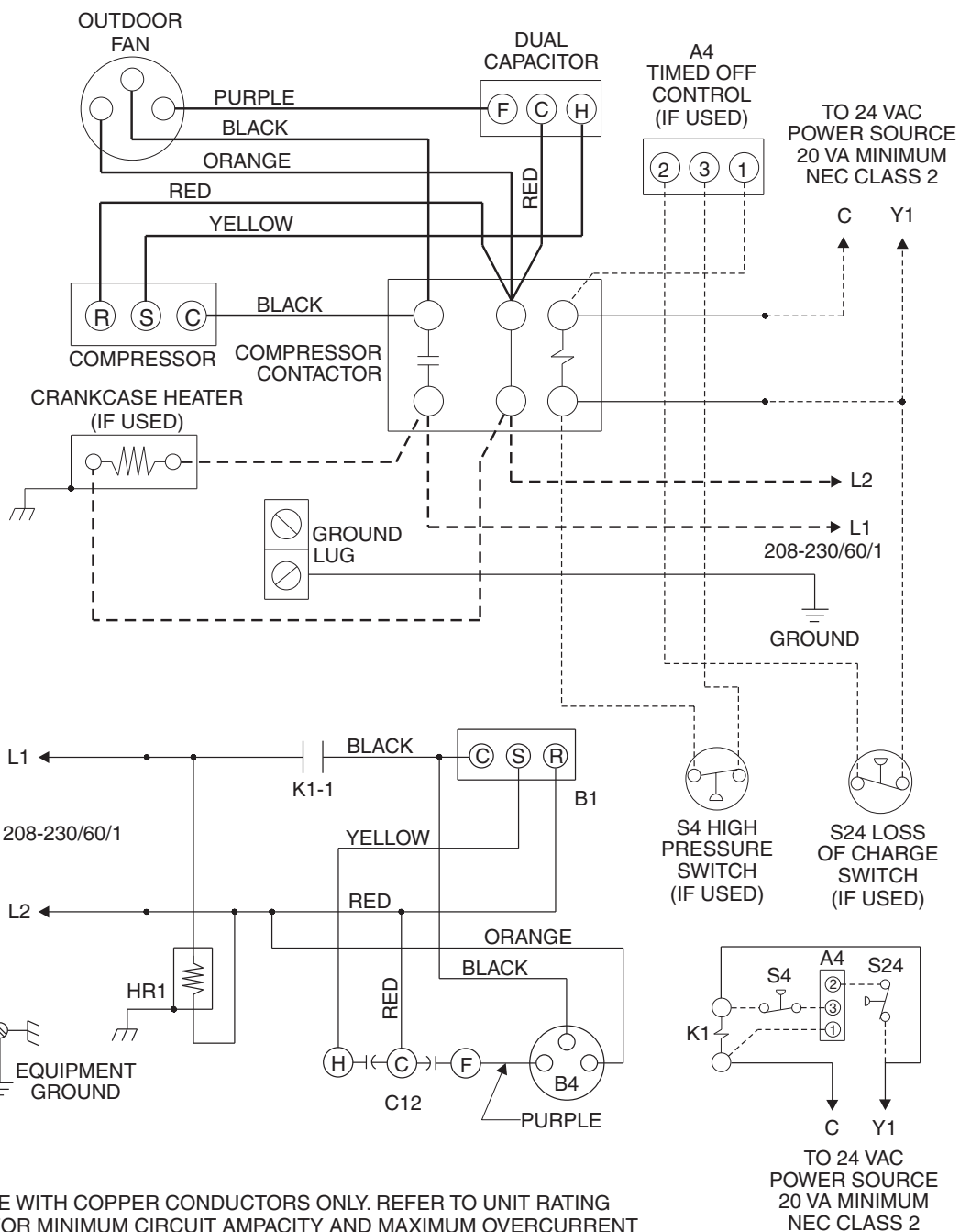

Single Phase Wiring Diagram P/N 48352-001

Figure 12

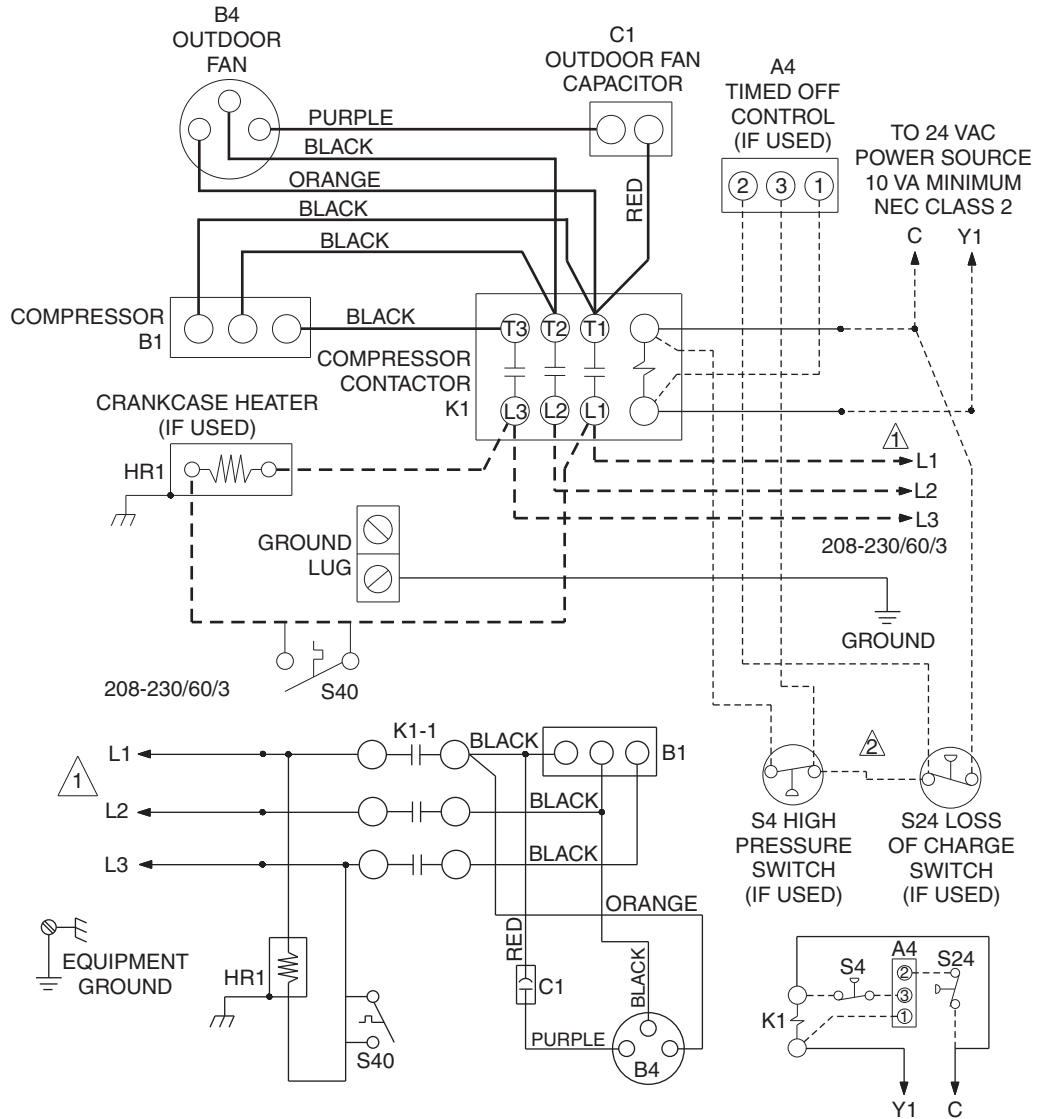

1 FOR USE WITH COPPER CONDUCTORS ONLY. REFER TO UNIT RATING PLATE FOR MINIMUM CIRCUIT AMPACITY AND MAXIMUM OVERCURRENT PROTECTION SIZE.

2 JUMPER IS USED WHEN TOC IS NOT USED.

WARNING--
ELECTRIC SHOCK HAZARD, CAN CAUSE INJURY OR DEATH. UNIT MUST BE GROUNDED IN ACCORDANCE WITH NATIONAL AND LOCAL CODES.

- LINE VOLTAGE FACTORY INSTALLED
- LINE VOLTAGE FIELD INSTALLED
- 24 VOLT FACTORY INSTALLED
- CLASS II VOLTAGE FIELD INSTALLED

DESCRIPTION	
KEY	COMPONENT
A4	CONTROL - TIMED OFF
B1	COMPRESSOR
B4	MOTOR - OUTDOOR FAN
C1	CAPACITOR - OUTDOOR FAN
HR1	HEATER - COMPRESSOR
K1-1	CONTACTOR - COMPRESSOR
S4	SWITCH - HIGH PRESSURE
S24	SWITCH - LOSS OF CHARGE
S40	THERMOSTAT - CRANKCASE

Three Phase Wiring Diagram P/N 48436-001

Figure 13

Limited Warranty

August 1, 1997

This warranty gives you specific legal rights and you may have other rights which vary from state/province to state/province.

Warrantor: Armstrong Air Conditioning Inc., 421 Monroe St., Bellevue, OH 44811

Armstrong Air Conditioning Inc. products are available under the following names: Air Ease, Armstrong Air, American Aire, Concord

Subject to the limitations stated in this warranty, we warrant to the first buyer for use the residential heating, cooling or heat pump unit, when installed, operated and maintained as required by this warranty, to be free of defects in workmanship or material for a period of 5 years (1 year for commercial equipment) from the time of installation. We will replace any defective component without cost or expense to you except for the costs of delivery and labor for removal and replacement of the defective component.

The 2SCU13LB Series air conditioners carry a 5-year compressor warranty. The 2SCU13LE Series air conditioners carry a 10-year compressor warranty.

Warranty Begins

The warranty period begins when the installation is complete and the product is ready to operate. You must be able to verify this date whenever a warranty claim is made. Original bill of sale, installer's invoice or other similar document will suffice. If the beginning date cannot be verified, we will consider warranty coverage to begin 6 months after the date the product was shipped from our factory.

Limitations on Implied Warranties

Implied warranties of merchantability or, to the extent applicable, fitness for a particular purpose are limited to 5 years, the same duration as the basic limited written warranty provided herein. Some states/provinces do not allow limitations on how long an implied warranty of merchantability or fitness lasts, so the above limitations or exclusions may not apply to you.

Only Warranty

This written Limited Warranty is the only warranty made by the warrantor; this warranty is in lieu of and excludes all other warranties, express or implied. The warrantor does not authorize any person to provide any other warranty or to assume for it any further obligation in connection with the warranted product.

What is NOT Covered

1. Cabinets or cabinet pieces.
2. Normal maintenance items such as filters, fan belts, fuses or other consumable items.
3. Damage caused by misuse, failure to maintain properly, accidents or acts of God.
4. External wiring, piping, venting or attachment of accessory products not integral to our product, including without limitation, humidifier, air cleaner, vent damper, thermostat or other mechanical devices not manufactured by the warrantor.
5. Products that have been operated in a corrosive atmosphere where a concentration of acids, halogenated hydrocarbons or other corrosive elements causes deterioration to metal surfaces or integral components. NOTE: Operation in a corrosive atmosphere is considered abuse and voids this warranty.
6. Products that have NOT been installed in accordance with our published installation instructions, applicable local, state/provincial or national codes, ACCA published standards.
7. Products that have NOT been installed by competent, qualified installers.
8. Products that have been moved from their original place of installation.

Warranty on Replacement Components

Any replacement component furnished by us will assume the remaining (unused) portion of the Limited Warranty.

Consequential Damages

The warrantor shall not be responsible for any consequential damages caused by any defect in the product. Some state/provinces do not allow the exclusion or limitations of incidental or consequential damages, so the above limitation or exclusion may not apply to you.

This product must be installed, used and cared for in accordance with the instruction manual. You are responsible for required periodic maintenance or service, such as changing or cleaning of air filters and lubrication or cleaning of components. Failure to properly install, operate or maintain your unit voids this warranty.